



EV9272-41

QC7I Single Head

Filter head exclusively for Everpure replacement cartridges



QC7I Single Head: EV9272-41

BENEFITS

Commercial quality filter head is designed exclusively to fit Everpure filter cartridges

Includes built-in water shut off valve

Includes mounting bracket and screws

Built-in water pressure gauge helps monitor proper flow

All wetted parts have passed NSF extraction tests

Engineered for durability, strength and longevity

Will not corrode

INSTALLATION TIPS

Mounts directly onto flat surface

Install vertically so cartridge hangs down

Allow 2-1/2" clearance below the cartridge for easy cartridge replacement

Flush filter by running water through filter according to cartridge instructions

OPERATION TIPS

Change cartridges on a regular 6 month preventative maintenance program

Change cartridges when capacity is reached or when pressure decreases

Always flush the filter cartridge at time of installation and cartridge change

APPLICATION/SIZING

For foodservice applications

Capacity: varies according to filter cartridge used

QC7I Single Head

SPECIFICATIONS

Overall Dimensions: 7.59" H x 8.04" W x 5.25" D

Inlet connection: 3/8"

Outlet connection: 3/8"

No electrical connection required

Shipping Weight: 1 lbs.

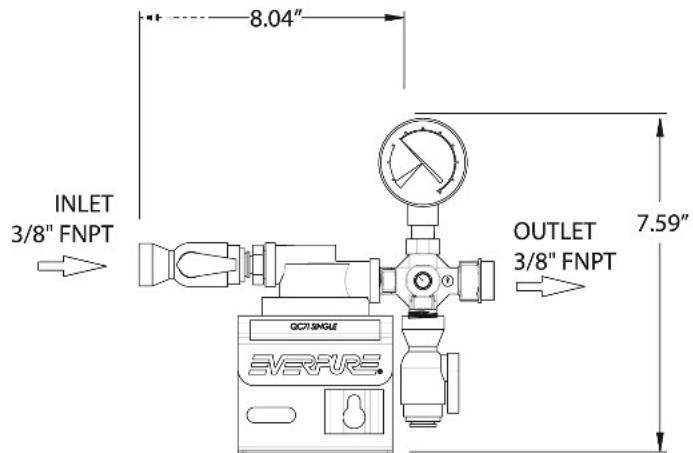

WARRANTY

Everpure water treatment systems (excluding replaceable elements) are covered by a limited warranty against defects in material and workmanship for a period of five years after date of purchase. Everpure replaceable elements (filter cartridges and water treatment cartridges) are covered by a limited warranty against defects in material and workmanship for a period of one year after date of purchase. See printed warranty for details. Everpure will provide a copy of the warranty upon request.



Liberty
Ersatzteile & Zubehör

Liberty Vertriebs GmbH
Bonner Straße 103
40589 Düsseldorf

Tel.: 0211-753520
Fax.: 0211-753575

Internet: www.libertyshop.de
Email: verkauf@libertyshop.de